

ISO/IEC JTC1/SC17 N 4329

DOCUMENT TYPE: TEXT FOR FDIS BALLOT

TITLE: Notification that –ISO/IEC 10373-6:2001/FPDAM 8.3 – Identification cards - Test methods - Part 6: Proximity cards - Amendment 8: Additional PICC classes– has been posted to the ISO server for FDIS ballot

BACKWARD POINTER: 3680, N 3681, N 3740, N 3822, N 3835, N 3836, N 3899, N 3960, N 3961, N 4029 ,N 4084, N 4085, N 4195 and N 4328

SOURCE: SECRETARIAT ISO/IEC JTC1/SC17

STATUS: Notification of FDIS ballot

ACTION ID: LB

WORK ITEM: 55242

DUE DATE: To be advised by ISO

DISTRIBUTION P, L and O-Members of ISO/IEC JTC1/SC17
JTC1 Secretariat
ISO/IEC ITTF

MEDIUM: SERVER

NO. OF PAGES: 21

	Explanatory Report	ISO/IEC FDIS
	ISO/IEC JTC 1/SC17 N 4329 Will supersede: SC 17 N 4085	Secretariat: APACS for BSI

This form should be sent to ITTF, together with the committee draft, by the secretariat of the joint technical committee or sub-committee concerned

The accompanying document is submitted for circulation to member body vote as a FDIS, following consensus of the P-members of the committee obtained on:	
	at the {DATE, LOCATION} meeting of ISO/IEC JTC 1/SC {YY} (See resolution number {XX} in document SC {YY} N {XXXXX})
✓	by postal ballot initiated on: 2010-11-17
P-members in favour:	Austria (ASI), Canada (SCC), China (SAC), Czech Republic (UNMZ), Denmark (DS), France (AFNOR), Germany (DIN), Israel (SII), Italy (UNI), Japan (JISC), Korea, Republic of (KATS), Netherlands (NEN), Norway (SN), Poland (PKN), Russian Federation (GOST R), Singapore (SPRING SG), Switzerland (SNV), United Kingdom (BSI), USA (ANSI)
P-members voting against:	
P-members abstaining:	Belgium (NBN), Finland (SFS), India (BIS), South Africa (SABS), Spain (AENOR), Sweden (SIS)
P-members who did not vote:	

Remarks: Comments resolved at the WG8 meeting, held in Ispra, Italy, on 2011-03-28/30. Dispositon contained in N 4328.	
Project: 55242	
I hereby confirm that this draft meets the requirements of part 2 of the IEC/ISO Directives	
Date: 2011-10-03	Name/Signature of the secretary: <div style="text-align: right; font-size: 1.2em;">Chris Starr</div>

ISO/IEC JTC 1/SC 17/WG 8 N

Date: 2011-10-02

ISO/IEC 10373-6:2011/FDAM 1:2011(E)

ISO/IEC JTC 1/SC 17/WG 8

Secretariat: DIN

Identification cards — Test methods — Part 6: Proximity cards

AMENDMENT 1

Additional PICC classes

Cartes d'identification — Méthodes d'essai — Partie 6: Cartes de proximité

AMENDEMENT 1

Classes additionnelles de PICC

Document type: International Standard
Document subtype: Amendment
Document stage: (50) Approval
Document language: E

C:\DOCUME~1\CHRISS~1\LOCALS~1\Temp\GWViewer\wg8n1801_Text_of_FDIS_10363-6_FDAM1_V20.doc STD Version 2.1c2

Copyright notice

This ISO document is a Draft International Standard and is copyright-protected by ISO. Except as permitted under the applicable laws of the user's country, neither this ISO draft nor any extract from it may be reproduced, stored in a retrieval system or transmitted in any form or by any means, electronic, photocopying, recording or otherwise, without prior written permission being secured.

Requests for permission to reproduce should be addressed to either ISO at the address below or ISO's member body in the country of the requester.

ISO copyright office
Case postale 56 • CH-1211 Geneva 20
Tel. + 41 22 749 01 11
Fax + 41 22 749 09 47
E-mail copyright@iso.org
Web www.iso.org

Reproduction may be subject to royalty payments or a licensing agreement.

Violators may be prosecuted.

Foreword

ISO (the International Organization for Standardization) and IEC (the International Electrotechnical Commission) form the specialized system for worldwide standardization. National bodies that are members of ISO or IEC participate in the development of International Standards through technical committees established by the respective organization to deal with particular fields of technical activity. ISO and IEC technical committees collaborate in fields of mutual interest. Other international organizations, governmental and non-governmental, in liaison with ISO and IEC, also take part in the work. In the field of information technology, ISO and IEC have established a joint technical committee, ISO/IEC JTC 1.

International Standards are drafted in accordance with the rules given in the ISO/IEC Directives, Part 2.

The main task of the joint technical committee is to prepare International Standards. Draft International Standards adopted by the joint technical committee are circulated to national bodies for voting. Publication as an International Standard requires approval by at least 75 % of the national bodies casting a vote.

Attention is drawn to the possibility that some of the elements of this document may be the subject of patent rights. ISO and IEC shall not be held responsible for identifying any or all such patent rights.

Amendment 1 to ISO/IEC 10373-6:2011 was prepared by Joint Technical Committee ISO/IEC JTC 1, *Information technology*, Subcommittee SC 17, *Cards and personal identification*.

Identification cards — Test methods — Part 6: Proximity cards

AMENDMENT 1: Additional PICC classes

Page 2 of ISO/IEC 10373-6:2011, 3.1

Add the following definition and renumber all subsequent definitions:

3.1.5

loading effect

a change in PCD antenna current caused by the presence of PICC(s) in the field due to the mutual coupling modifying the PCD antenna resonance and quality factor

Page 3 of ISO/IEC 10373-6:2011, 3.2

Add the following symbol:

V_{load} DC voltage measured at connector CON3 of the Reference PICC

Page 6 of ISO/IEC 10373-6:2011, Clause 5

Replace subclause 5.2 by the following:

5.2 Calibration coils

This clause defines the size, thickness and characteristics of the calibration coils 1 and 2.

Calibration coil 1 shall be used only in test PCD assembly 1 and calibration coil 2 shall be used only in test PCD assembly 2.

5.2.1 Size of the calibration coil card

The calibration coil card shall consist of an area which has the height and width of an ID-1 type defined in ISO/IEC 7810:2003 containing a single turn coil concentric with the card outline (see Figure 1).

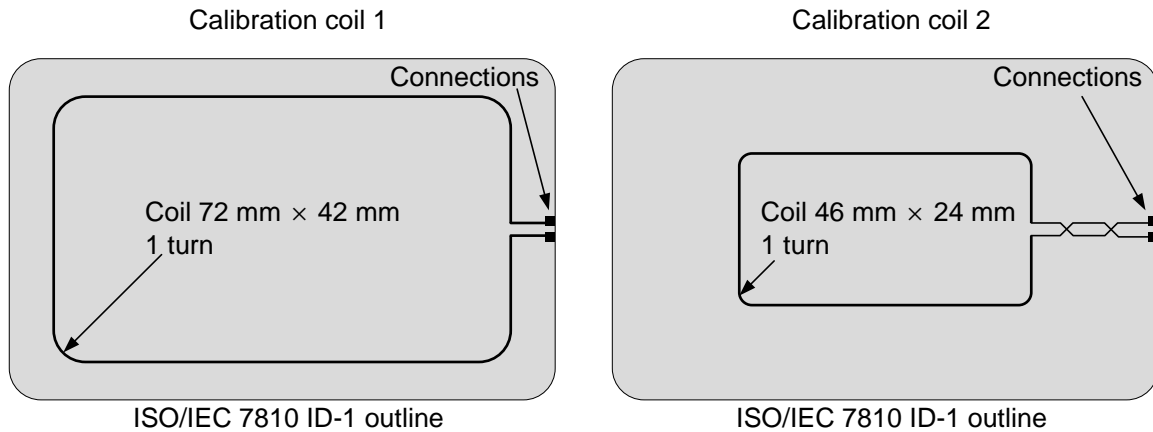

Figure 1 — Calibration coils 1 and 2

5.2.2 Thickness and material of the calibration coil card

The thickness of the calibration coil card shall be less than that of an ID-1 card. It shall be constructed of a suitable insulating material.

5.2.3 Coil characteristics

The coil on the calibration coil card shall have one turn. Relative dimensional tolerance shall be $\pm 2\%$.

The outer size of the calibration coil 1 shall be 72 mm x 42 mm with corner radius 5 mm.

NOTE 1 The area over which the field is integrated is approximately 3000 mm².

NOTE 2 At 13,56 MHz the approximate inductance is 250 nH and the approximate resistance is 0,4 Ω .

The open circuit calibration factor for the calibration coil 1 is 0,318 V (rms) per A/m (rms) [Equivalent to 900 mV (peak-to-peak) per A/m (rms)].

The outer size of the calibration coil 2 shall be 47 mm x 24 mm with corner radius 2 mm.

NOTE 3 The area over which the field is integrated is approximately 1100 mm².

NOTE 4 At 13,56 MHz the approximate inductance is 140 nH and the approximate resistance is 0,3 Ω .

The open circuit calibration factor for the calibration coil 2 is 0,118 V (rms) per A/m (rms) [Equivalent to 333 mV (peak-to-peak) per A/m (rms)].

The coil shall be made as a printed coil on printed circuit board (PCB) plated with 35 μm copper. Track width shall be 500 μm with a relative tolerance of $\pm 20\%$. The size of the connection pads shall be 1,5 mm x 1,5 mm.

A high impedance oscilloscope probe with an input admittance equivalent to a parallel capacitance $C_p < 14$ pF and a parallel resistance $R_p > 9$ k Ω at 13,56 MHz shall be used to measure the (open circuit) voltage induced in the coil.

NOTE 5 The high impedance oscilloscope probe ground connection should be as short as possible, less than 20 mm or coaxial connection.

Page 7 of ISO/IEC 10373-6:2011, Clause 5

Replace 5.3 by the following:

5.3 Test PCD assembly

Two test PCD assemblies are defined:

- Test PCD assembly 1 for PICCs of classes 1, 2 and 3 and for PICCs which do not claim compliance with a class;
- Test PCD assembly 2 for PICCs of classes 4, 5 and 6.

Each test PCD assembly shall consist of a circular test PCD antenna and two parallel sense coils: sense coil a and sense coil b. The test set-up is shown in Figure 2. The sense coils shall be connected such that the signal from one coil is in opposite phase to the other. The $10\ \Omega$ potentiometer P1 serves to fine adjust the balance point when the sense coils are not loaded by a PICC or any magnetically coupled circuit. The capacitive load of the probe including its parasitic capacitance shall be less than $14\ \text{pF}$.

NOTE 1 The capacitance of the connections and of the oscilloscope probe should be kept to a minimum for reproducibility.

NOTE 2 In order to avoid any unintended misalignment in case of an unsymmetrical set-up the tuning range of the potentiometer P1 is only $10\ \Omega$. If the set-up cannot be compensated by the $10\ \Omega$ potentiometer P1 the overall symmetry of the set-up should be checked.

NOTE 3 The high impedance oscilloscope probe ground connection should be as short as possible, less than 20 mm or coaxial connection.

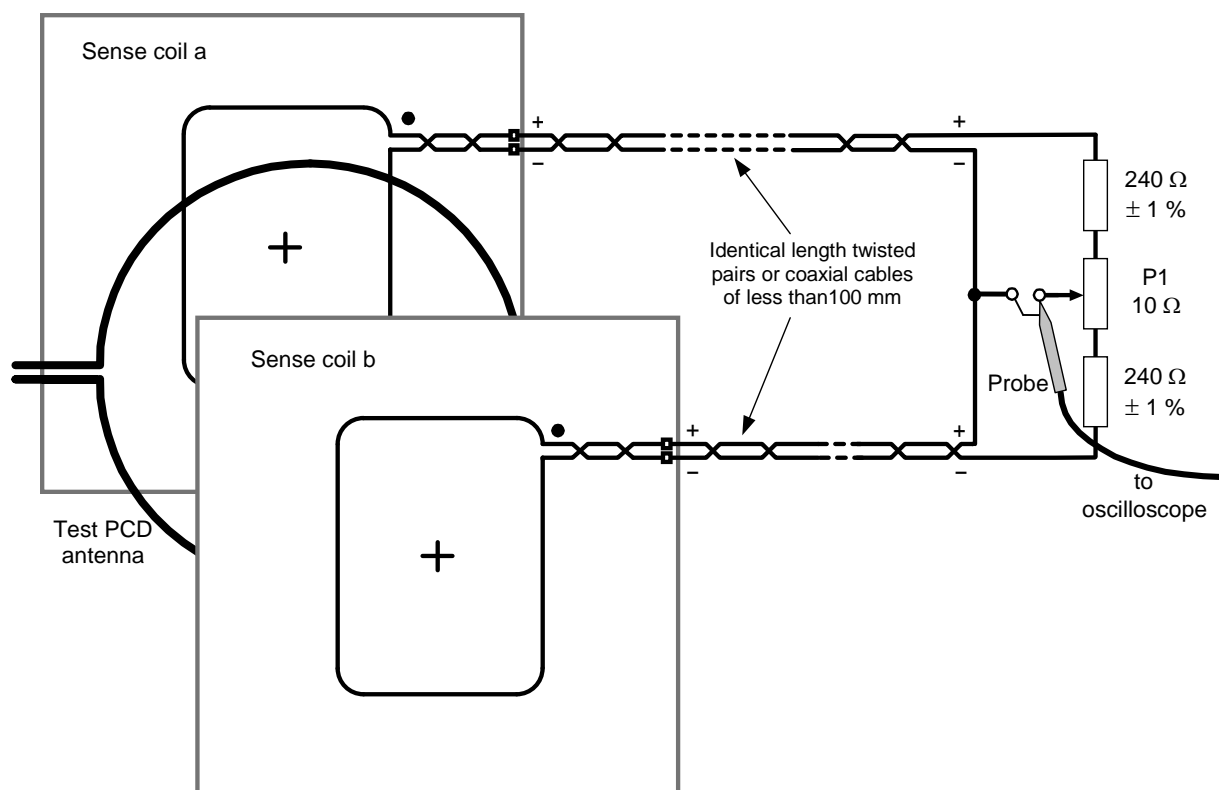

Figure 2 — Test set-up (principle)

5.3.1 Test PCD antenna

In test PCD assembly 1 the test PCD antenna 1 shall have a diameter of 150 mm.

In test PCD assembly 2 the test PCD antenna 2 shall have a diameter of 100 mm.

Each test PCD antenna construction shall conform to the corresponding drawings in Annex A.

The matching of each test PCD antenna should be accomplished by using an impedance analyzer or a network analyzer or an LCR meter. If either an impedance analyzer or a network analyzer or an LCR meter is not available, then the matching may be accomplished with the procedure given in Annex B.

5.3.2 Sense coils

In test PCD assembly 1 the size of the sense coils 1 shall be 100 mm × 70 mm with corner radius 10 mm.

In test PCD assembly 2 the size of the sense coils 2 shall be 60 mm × 47 mm with corner radius 10 mm.

Each sense coil construction shall conform to the corresponding drawings in Annex C.

5.3.3 Assembly of Test PCD

The sense coils 1 and test PCD antenna 1 shall be assembled parallel and with the sense and antenna coils coaxial and such that the distance between the active conductors is 37,5 mm as shown in Figure 3.

The sense coils 2 and test PCD antenna 2 shall be assembled parallel and with the sense and antenna coils coaxial and such that the distance between the active conductors is 23 mm as shown in Figure 3.

The dimensional tolerance shall be better than $\pm 0,5$ mm. The distance between the coil in the DUT and the calibration coil shall be equal with respect to the coil of the test PCD antenna.

NOTE These distances are chosen to offer a strong and homogenous magnetic field in the DUT position.

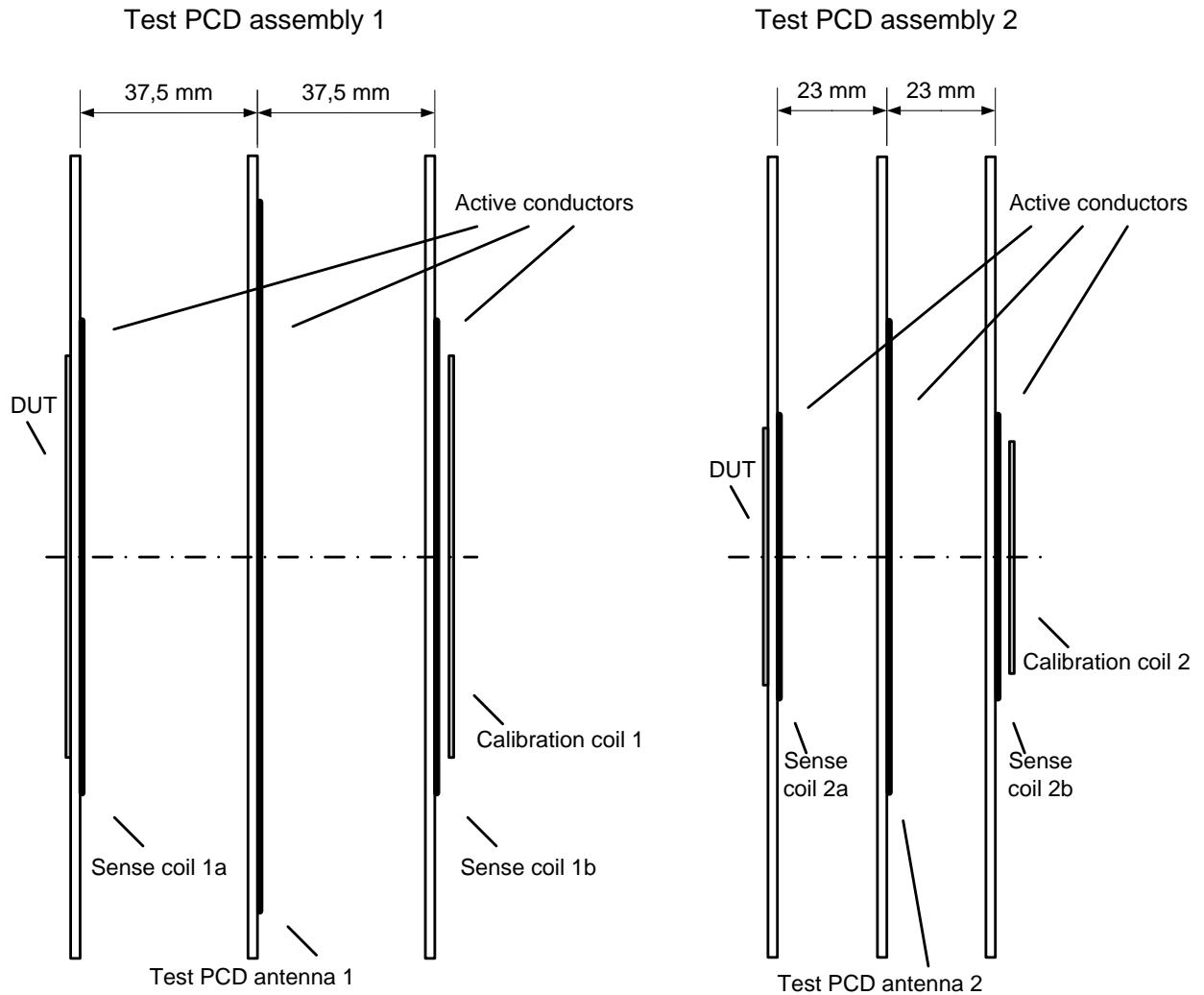

Figure 3 — Test PCD assembly 1 and test PCD assembly 2

Page 10 of ISO/IEC 10373-6:2011, 5.4.2

Replace 1st paragraph with:

"The Reference PICCs coils layouts are defined in Annex D. If connectors are used between the coils and the circuitry those connectors shall have minimal, if any, effect on the RF measurements."

Page 11 of ISO/IEC 10373-6:2011, 5.4.3

Replace "6 V" by " V_{load} " in steps f), g) and i) and in NOTE.

Page 12 of ISO/IEC 10373-6:2011, 6.2.1.2

Replace step a) with:

ISO/IEC 10373-6:2011/FDAM 1:2011(E)

- a) Adjust the RF power delivered by the signal generator to the test PCD antenna to a field strength of the average level specified in ISO/IEC 14443-1, 4.4 as measured by the calibration coil."

Page 13 of ISO/IEC 10373-6:2011, 6.2.1.2

Replace step d) with:

- d) Adjust the RF power delivered by the signal generator to the test PCD antenna to a field strength of the maximum level specified in ISO/IEC 14443-1, 4.4 as measured by the calibration coil.

Page 13 of ISO/IEC 10373-6:2011, 6.2.1.2

Replace step f) with:

- f) Apply for 5 min an ASK 100 % modulation to this field with the following duty cycle:
- 5 s at 0 A/m (rms);
 - 25 s at of the maximum level specified in ISO/IEC 14443-1, 4.4.

Page 14 of ISO/IEC 10373-6:2011, 7.1

Replace the paragraph with the following paragraphs, table and note:

All the PCD tests described below will be done in the operating volumes as defined by the PCD manufacturer for each supported class.

All PCD tests of ISO/IEC 14443-2 parameters shall be performed using Reference PICCs 1, 2 and 3 and optionally other Reference PICCs corresponding to the optional classes supported by the PCD, with the relevant parameters and test PCD assembly as defined in Table 3.

Table 3 — Classes parameters

Class	Reference PICC	V_{load}	$R2_{min}$	$R2_{max}$	Test PCD assembly
1	1	6 V	870 Ω	1070 Ω	Test PCD assembly 1
2	2	4,5 V	1030 Ω	1260 Ω	Test PCD assembly 1
3	3	4,5 V	1080 Ω	1320 Ω	Test PCD assembly 1
4	4	4,5 V	990 Ω	1210 Ω	Test PCD assembly 2
5	5	4,5 V	960 Ω	1170 Ω	Test PCD assembly 2
6	6	4,5 V	900 Ω	1100 Ω	Test PCD assembly 2

NOTE V_{load} may be harmonized to 4,5 V for all classes in future revisions of ISO/IEC 10373-6.

Page 16 of ISO/IEC 10373-6:2011, 7.1.1

Add the following paragraph:

"The maximum and minimum field strength values to be used with each Reference PICC are given in ISO/IEC 14443-2:2010/Amd.2:2011, Table 1."

Page 15 of ISO/IEC 10373-6:2011, 7.1.1.2

Replace the Procedure for H_{\min} test with:

- a) Tune the Reference PICC to 13,56 MHz as described in 5.4.3.
- b) Place the Reference PICC into the DUT position on the Test PCD assembly producing the H_{\min} operating condition on the calibration coil. Check that the jumper J1 is set to position 'b' and that a DC voltage of V_{load} as defined in Table 3 is measured at connector CON3. Alternatively, the jumper J1 may be set to position 'c' and the voltage on CON2 is adjusted to obtain a DC voltage of V_{load} as defined in Table 3 at connector CON3. In both cases, the operating field condition shall be verified by monitoring the voltage on the calibration coil and adjusted if necessary.

WARNING - R2 value should be between $R2_{\min}$ and $R2_{\max}$ as defined in Table 3. Check this range at least once before using the alternative method.

- c) Position the Reference PICC within the defined operating volume of the PCD under test. The DC voltage at CON3 shall exceed V_{load} as defined in Table 3.

Page 15 of ISO/IEC 10373-6:2011, 7.1.1.3

Replace the paragraph with:

"The test report shall confirm the operating volume in which the DC voltage measured at CON3 for R2 or variable load resistor adjusted to H_{\min} and H_{\max} field strength fulfils the requirements defined in steps d) of the two procedures of 7.1.1.2."

Page 15 of ISO/IEC 10373-6:2011, Clause 7

Delete 7.1.2 and its subclauses.

Page 16 of ISO/IEC 10373-6:2011, Clause 7

Delete 7.1.3 and its subclauses.

Page 16 of ISO/IEC 10373-6:2011, 7.1.4.2

Replace step d) by the following:

"d) Apply and adjust a DC voltage at CON2 to obtain a DC voltage at connector CON3 of V_{load} as defined in Table 3."

Page 17 of ISO/IEC 10373-6:2011, 7.1.5.2

Replace step c) by the following:

"c) Apply and adjust a DC voltage at CON2 to obtain a DC voltage at connector CON3 of V_{load} as defined in Table 3."

Page 18 of ISO/IEC 10373-6:2011, 7.2.1.2

Replace the first paragraph starting with "Step 1" with:

"Step 1: The load modulation test circuit of Figure 2 and the test PCD assembly of Figure 3 defined for the PICC class (see ISO/IEC 14443-2:2010/Amd.2:2011, 8.2.2) are used. If the PICC does not claim to meet the requirements of one particular class as specified in ISO/IEC 14443-1:2008/Amd.1:2011, then select the test PCD assembly 1."

Page 21 of ISO/IEC 10373-6:2011, 7.2.4

Replace 7.2.4 and its subclauses with the following:

7.2.4 PICC maximum loading effect

7.2.4.1 Purpose

This test is used to measure the PICC loading effect.

7.2.4.2 Test procedure

Depending on the claimed PICC class, select:

- the relevant H_{min} as defined in ISO/IEC 14443-2:2010/Amd.2:2011, Table 2;
- the relevant Reference PICC as defined in Table 3 and its reference voltage V_{load} ;
- the relevant test PCD assembly as defined in Table 3.

If the PICC does not claim any particular class as specified in ISO/IEC 14443-1:2008/Amd.1:2011, then "Class 1" parameters, test apparatus and circuits shall be used for this test.

The PICC loading effect at H_{min} shall be measured using the Test PCD assembly. It shall not exceed the loading effect of the selected Reference PICC tuned to 13,56 MHz and calibrated to obtain V_{load} at CON3 at H_{min} . The procedure of this substitution method is as follows.

- a) Tune the selected Reference PICC to 13,56 MHz as described in 5.4.3.
- b) Calibrate the Test PCD assembly to produce the H_{min} operating condition on the calibration coil.
- c) Place the Reference PICC into the DUT position on the Test PCD assembly. Switch the jumper J1 to position 'b' and adjust R2 to obtain a DC voltage of V_{load} measured at connector CON3. Alternatively, jumper J1 may be set to position 'c' and the applied voltage on CON2 is adjusted to obtain a DC voltage of V_{load} at connector CON3. In both cases, the operating field condition shall be verified by monitoring the voltage on the calibration coil and adjusted if necessary.

WARNING — R2 value should be between $R2_{\min}$ and $R2_{\max}$ as defined in Table 3. Check this range at least once before using the alternative method.

- d) Remove the Reference PICC.
- e) Place the PICC under test into the DUT position on the Test PCD assembly.
- f) Measure the field strength monitored by the calibration coil.

This field strength shall be greater than H_{\min} .

7.2.4.3 Test report

The test report shall give the value of the measured field strength.

Page 23 of ISO/IEC 10373-6:2011, Annex A

Replace all occurrences of "test PCD antenna" with "test PCD antenna 1".

Add a new subclause at the end of Annex A:

A.3 Test PCD antenna 2

A.3.1 Test PCD antenna 2 layout including impedance matching network

Figures A.7 and A.8 illustrate the Test PCD antenna 2 layout. Drawings are not to scale.

The antenna coil track width is 1,8 mm (except for through-plated holes).

Starting from the impedance matching network there are crossovers every 45 °.

Printed circuit board (PCB): FR4 material, thickness 1,6 mm, double sided with 35 µm copper.

NOTE 1 The layout and the position of the impedance matching network are informative. The outer PCB dimensions are informative.

NOTE 2 Such printed circuit boards and R_{ext} resistors are available from various commercial sources.

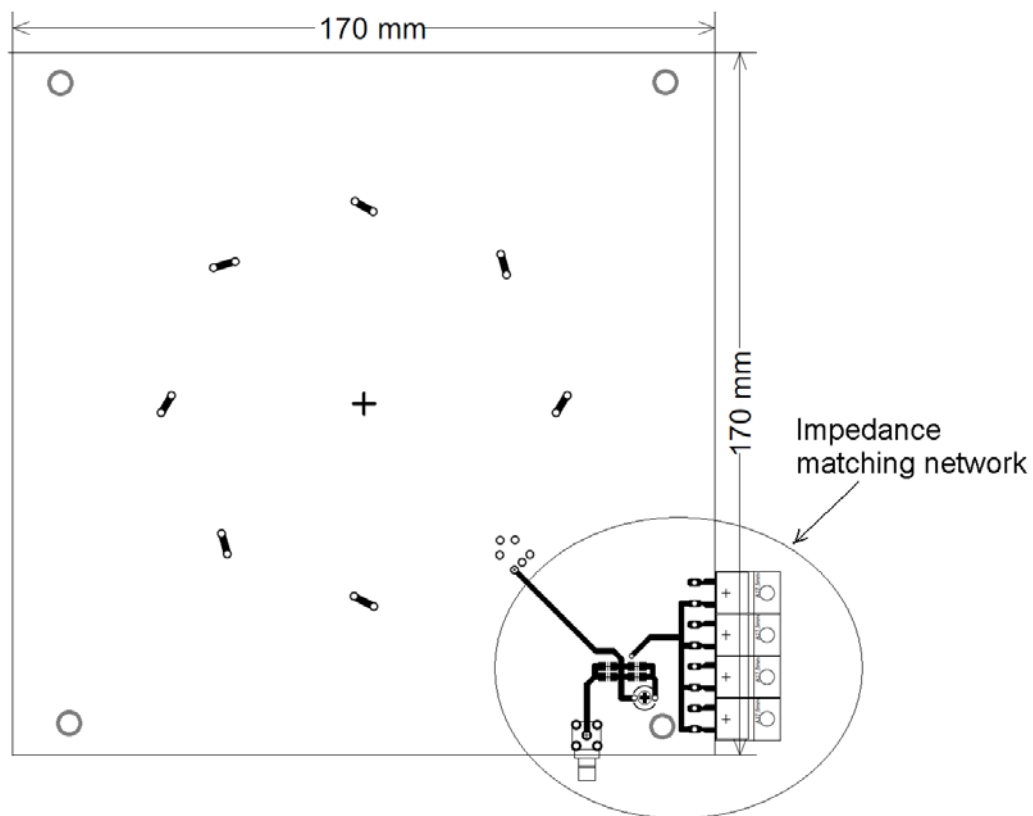

Figure A.7 — Test PCD antenna 2 layout including impedance matching network (view from front)

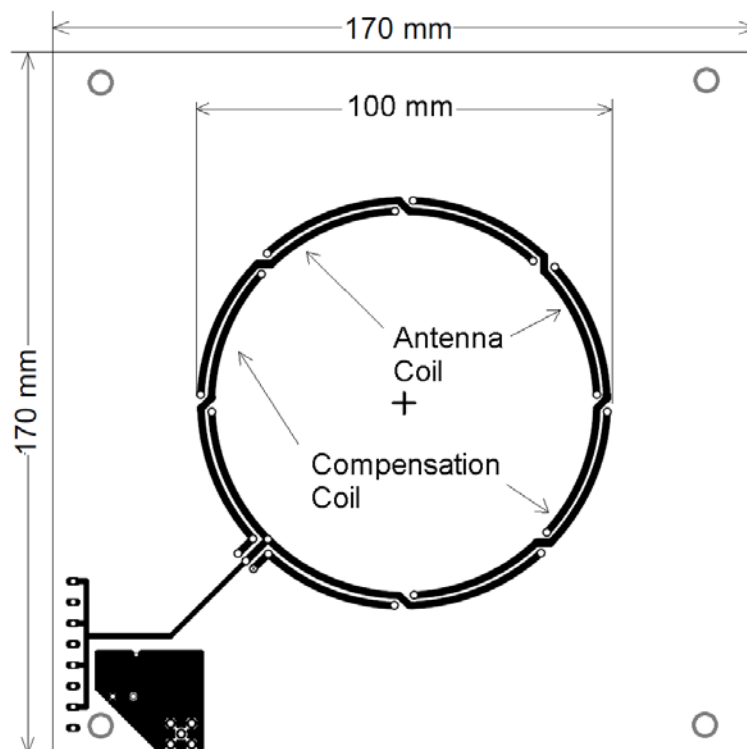

Figure A.8 — Test PCD antenna 2 layout including impedance matching network (view from back)

A.3.2 Impedance matching network 2

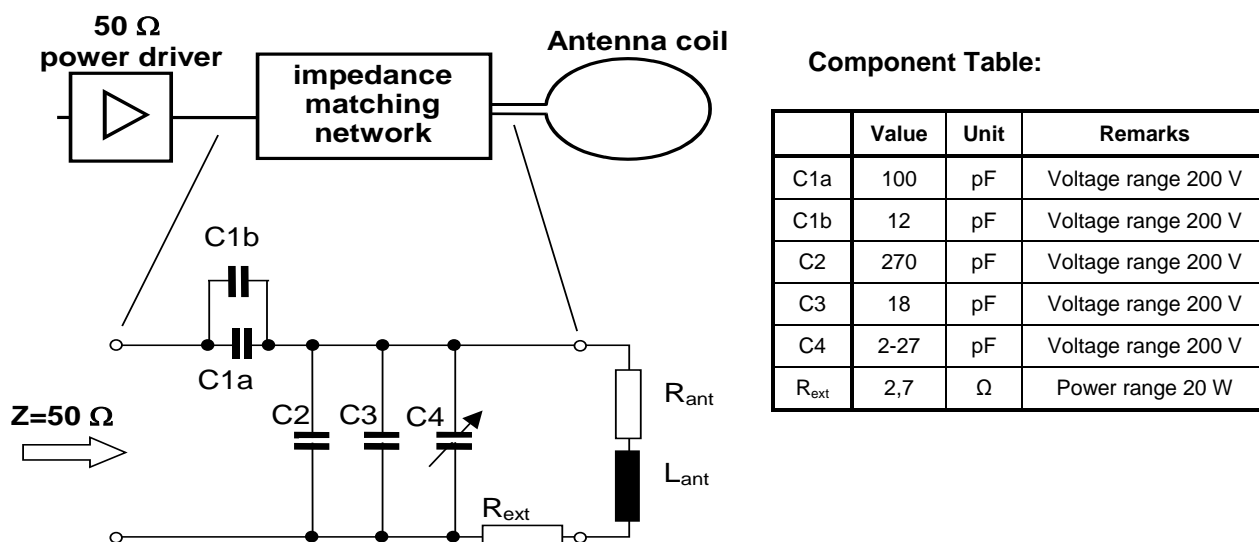

Figure A.9 — Impedance matching network 2

NOTE 1 R_{ext} may be built by either a parallel circuit composed of two equal branches having two resistors of 2,7 Ω 5 W in series each or a parallel circuit of 10 Ω, 10 Ω, 10 Ω and 15 Ω, 5 W.

NOTE 2 R_{ext} should be placed on the GND side of the antenna as drawn.

NOTE 3 The parasitic capacitance of the antenna is not shown in Figure A.9.

Page 31 of ISO/IEC 10373-6:2011, Annex C

Add following sub clause headline directly after C.1:

C.1.1 Sense coil 1 layout

Change the first sentence with "Figure C.1 illustrates the sense coils 1 layout."

Replace "Figure C.1 — Layout for sense coils a and b" with "Figure C.1 — Layout for sense coils 1 (a and b)".

Page 32 of ISO/IEC 10373-6:2011, Annex C

Add following sub clause before C.2 and renumber figures in Annex C:

C.1.2 Sense coil 2 layout

Figure C.2 illustrates the sense coils 2 layout. Drawings are not to scale.

The sense coil track width is 0,5 mm with relative tolerance $\pm 20\%$ (except for through-plated holes). Size of the coils refers to the outer dimensions.

Printed circuit board (PCB): FR4 material, thickness 1,6 mm, double sided with 35 μm copper.

NOTE Such printed circuit boards are available from various commercial sources.

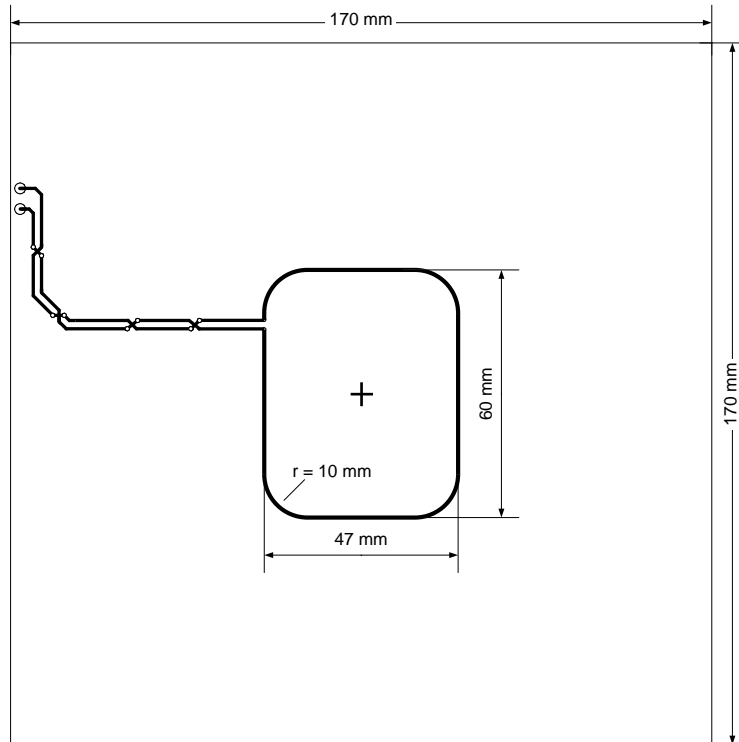

Figure C.2 — Layout for sense coils 2 (a and b)

Page 33 of ISO/IEC 10373-6:2011, Annex D

Change the title to "Reference PICCs".

Page 33 of ISO/IEC 10373-6:2011, D.1

Add a subclause title:

"D.1 Reference PICC 1 coil layouts"

Change the first sentence with:

"Figure D.1 specifies the Reference PICC 1 Pick up coil and Main coil layouts."

Change title of figure D.1 to:

“Figure D.1 – Reference PICC 1 Pick up coil and Main coil layouts”

Page 33 of ISO/IEC 10373-6:2011, Annex D

Add following sub clauses at the end of D.1:

D.2 Reference PICC 2 coil layouts

Figure D.2 specifies the Reference PICC 2 Pick up coil and Main coil layouts.

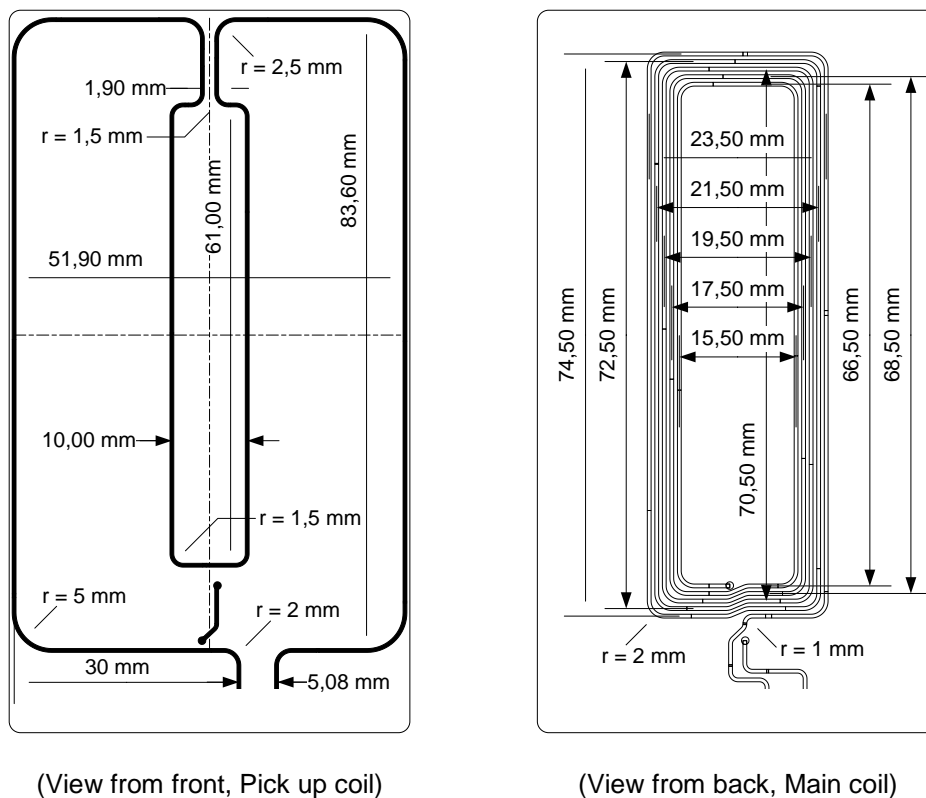

Figure D.2 — Reference PICC 2 Pick up coil and Main coil layouts

Dimensions to track center (drawings are not to scale).

Main coil dimensions: 75 mm x 24 mm (outer dimensions).

The Pick up coil and the Main coil shall be concentric.

The two coils track width and spacing shall be 0,5 mm with a relative tolerance of $\pm 20\%$.

All main coil corners radii shall be 2 mm.

Printed circuit board (PCB): FR4 material, thickness 0,76 mm with a relative tolerance of $\pm 10\%$, double sided with 35 μm copper.

NOTE 1 At 13,56 MHz the inductance of the Main coil L1 is 2,4 $\mu\text{H} \pm 10\%$ and the resistance is 1,9 $\Omega \pm 10\%$.

NOTE 2 At 13,56 MHz the inductance of the Pick up coil L2 is 417 nH $\pm 10\%$ and the approximate resistance is 0,8 $\Omega \pm 10\%$.

D.3 Reference PICC 3 coil layouts

Figure D.3 specifies the Reference PICC 3 Pick up coil and Main coil layouts.

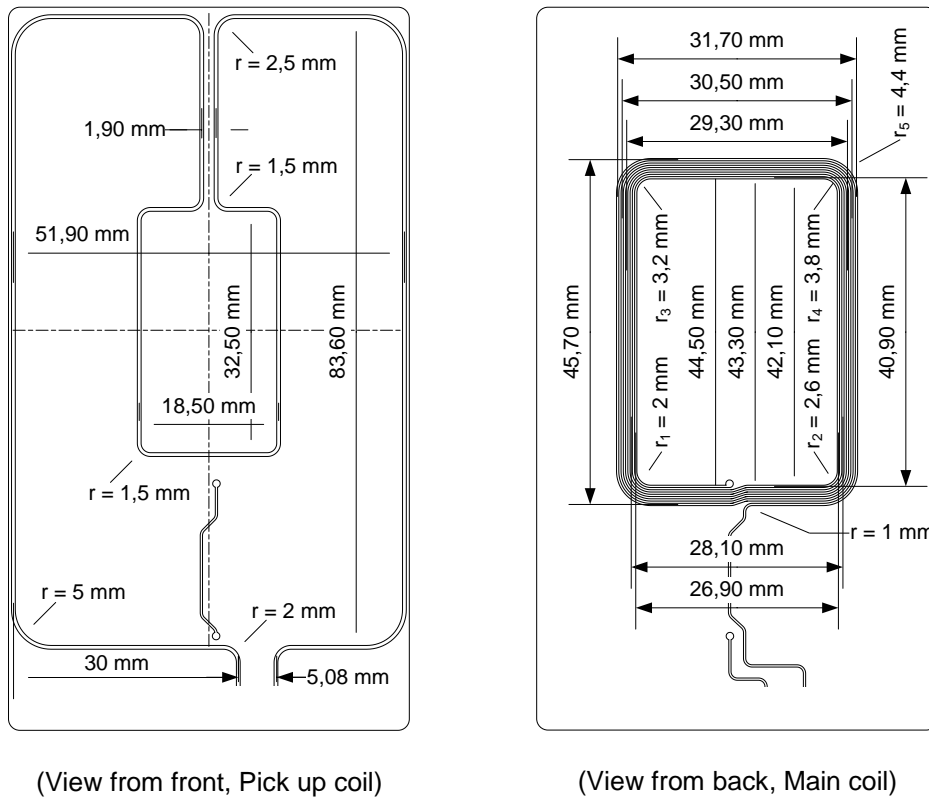

Figure D.3 — Reference PICC 3 Pick up coil and Main coil layouts

Dimensions to track center (drawings are not to scale).

Main coil dimensions: 46 mm x 32 mm (outer dimensions).

The Pick up coil and the Main coil shall be concentric.

The Pick up coil track width shall be 0,5 mm with a relative tolerance of $\pm 20 \%$.

The Main coil track width and spacing shall be 0,3 mm with a relative tolerance of $\pm 20 \%$.

Printed circuit board (PCB): FR4 material, thickness 0,76 mm with a relative tolerance of $\pm 10 \%$, double sided with 35 μm copper.

NOTE 1 At 13,56 MHz the inductance of the Main coil L1 is 2,39 $\mu\text{H} \pm 10 \%$ and the resistance is 2,18 $\Omega \pm 10 \%$.

NOTE 2 At 13,56 MHz the inductance of the Pick up coil L2 is 405 nH $\pm 10 \%$ and the approximate resistance is 0,76 $\Omega \pm 10 \%$.

D.4 Reference PICC 4 coil layouts

Figure D.4 specifies the Reference PICC 4 Pick up coil and Main coil layouts.

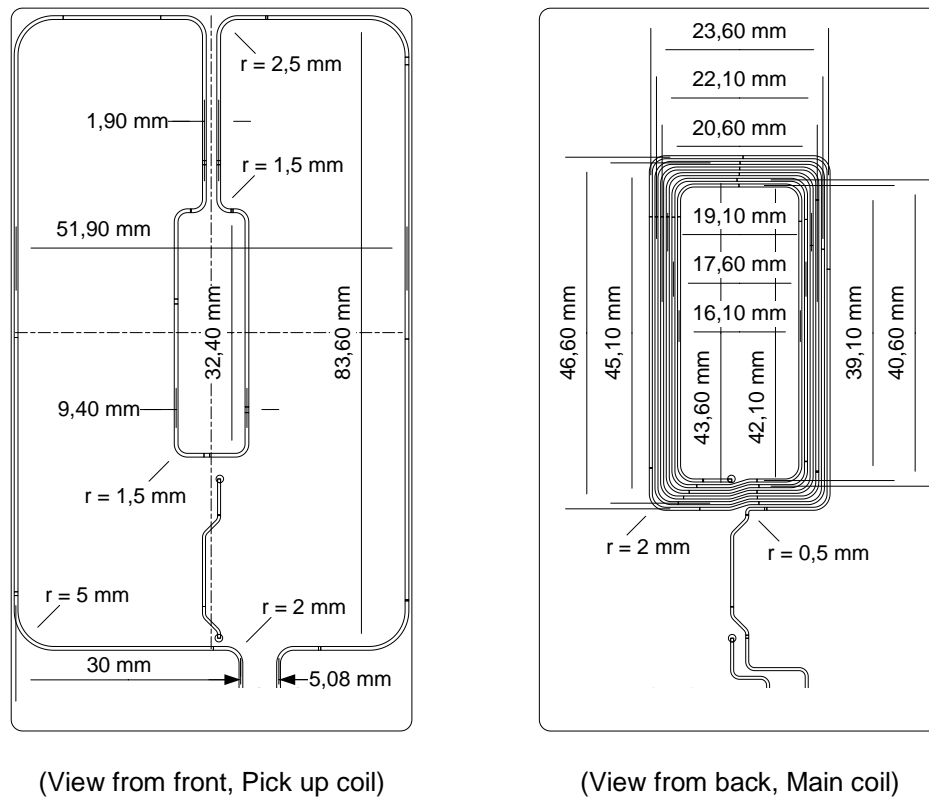

Figure D.4 — Reference PICC 4 Pick up coil and Main coil layouts

Dimensions to track center (drawings are not to scale).

Main coil dimensions: 47 mm x 24 mm (outer dimensions).

The Pick up coil and the Main coil shall be concentric.

The Pick up coil track width shall be 0,5 mm with a relative tolerance of $\pm 20\%$.

All main coil corners radii shall be 2 mm.

The Main coil track width shall be 0,4 mm and the spacing shall be 0,35 mm with a relative tolerance of $\pm 20\%$.

Printed circuit board (PCB): FR4 material, thickness 0,76 mm with a relative tolerance of $\pm 10\%$, double sided with 35 μm copper.

NOTE 1 At 13,56 MHz the inductance of the Main coil L1 is 2,3 $\mu\text{H} \pm 10\%$ and the resistance is 1,8 $\Omega \pm 10\%$.

NOTE 2 At 13,56 MHz the inductance of the Pick up coil L2 is 390 nH $\pm 10\%$ and the approximate resistance is 0,7 $\Omega \pm 10\%$.

D.5 Reference PICC 5 coil layouts

Figure D.5 specifies the Reference PICC 5 Pick up coil and Main coil layouts.

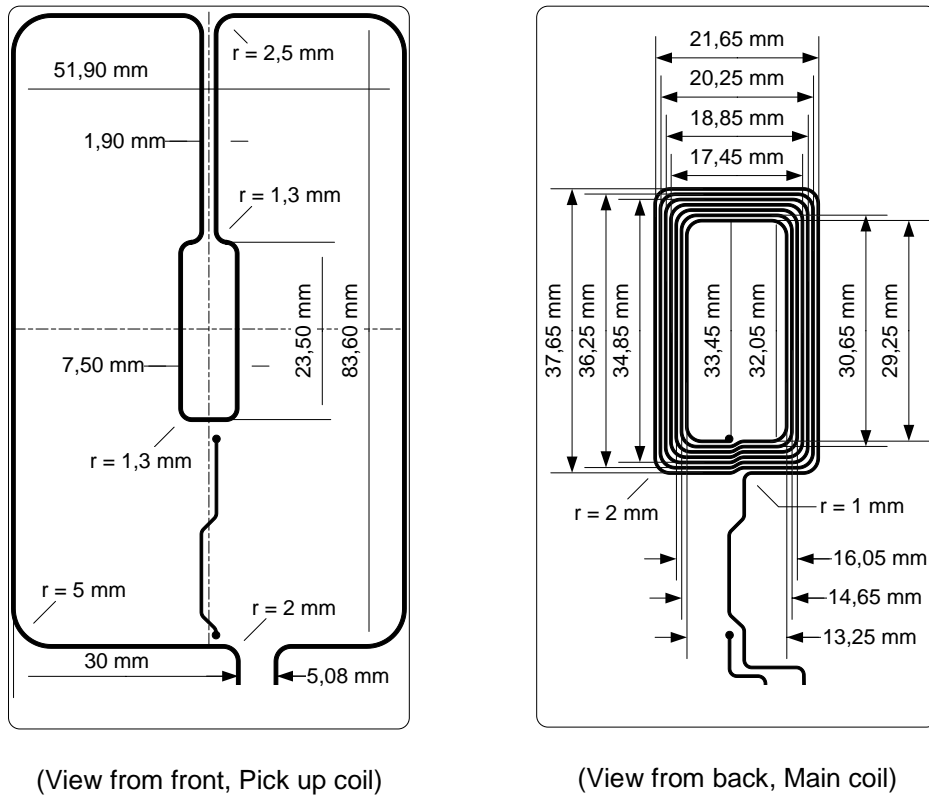

Figure D.5 — Reference PICC 5 Pick up coil and Main coil layouts

Dimensions to track center (drawings are not to scale).

Main coil dimensions: 38 mm x 22 mm (outer dimensions).

The Pick up coil and the Main coil shall be concentric.

The Pick up coil track width shall be 0,5 mm with a relative tolerance of $\pm 20 \%$.

All main coil corners radii shall be 2 mm.

The Main coil track width and spacing shall be 0,35 mm with a relative tolerance of $\pm 20 \%$.

Printed circuit board (PCB): FR4 material, thickness 0,76 mm with a relative tolerance of $\pm 10 \%$, double sided with 35 μm copper.

NOTE 1 At 13,56 MHz the inductance of the Main coil L1 is 2,4 $\mu\text{H} \pm 10 \%$ and the resistance is 1,9 $\Omega \pm 10 \%$.

NOTE 2 At 13,56 MHz the inductance of the Pick up coil L2 is 380 nH $\pm 10 \%$ and the approximate resistance is 0,7 $\Omega \pm 10 \%$.

D.6 Reference PICC 6 coil layouts

Figure D.6 specifies the Reference PICC 6 Pick up coil and Main coil layouts.

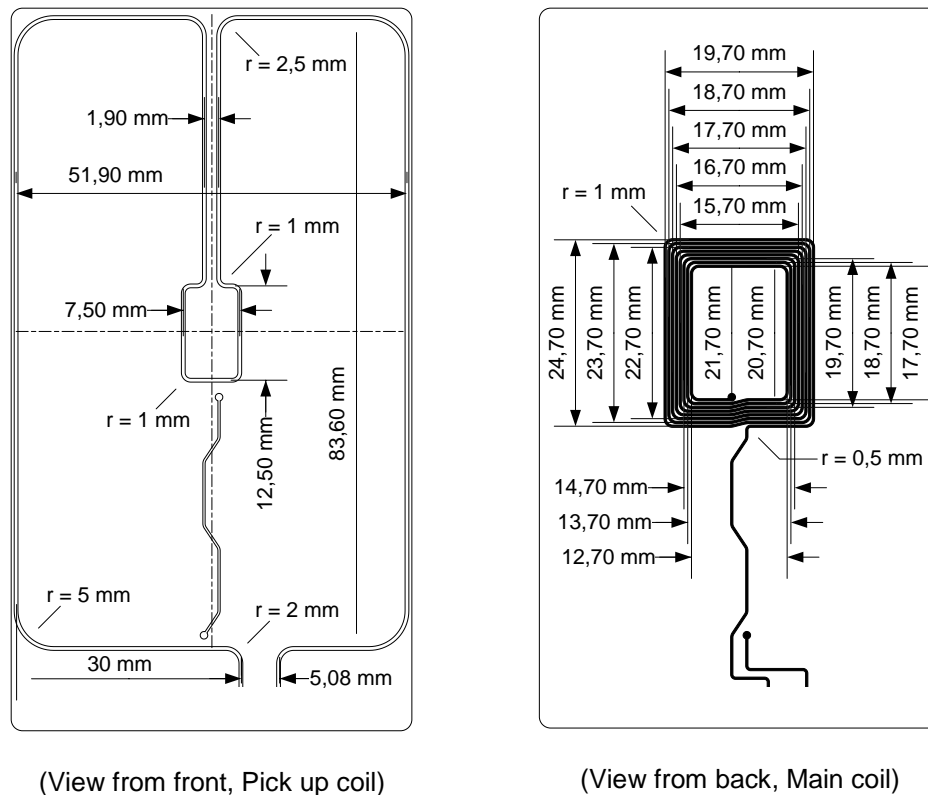

Figure D.6 — Reference PICC 6 Pick up coil and Main coil layouts

Dimensions to track center (drawings are not to scale).

Main coil dimensions: 25 mm x 20 mm (outer dimensions).

The Pick up coil and the Main coil shall be concentric.

The Pick up coil track width shall be 0,5 mm with a relative tolerance of $\pm 20\%$.

All main coil corners radii shall be 1 mm.

The Main coil track width shall be 0,3 mm and the spacing shall be 0,2 mm with a relative tolerance of $\pm 20\%$.

Printed circuit board (PCB): FR4 material, thickness 0,76 mm with a relative tolerance of $\pm 10\%$, double sided with 35 μm copper.

NOTE 1 At 13,56 MHz the inductance of the Main coil L1 is 2,3 $\mu\text{H} \pm 10\%$ and the resistance is 2,2 $\Omega \pm 10\%$.

NOTE 2 At 13,56 MHz the inductance of the Pick up coil L2 is 370 nH $\pm 10\%$ and the approximate resistance is 0,7 $\Omega \pm 10\%$.