

**ISO/IEC JTC1/SC17 N 3619**

**WG8 N 1497**

**DOCUMENT TYPE: Notification of Ballot**

**TITLE:** Notification of Ballot: ISO/IEC CD 15693-1 (Revision): Identification cards – Contactless integrated circuit cards – Vicinity cards – Part 1: Physical characteristics

**BACKWARD POINTER:**

**SOURCE:** SECRETARIAT ISO/IEC JTC1/SC17

**STATUS:** This ballot has been posted to the ISO Electronic balloting application and is available under the Balloting Portal, Committee Internal Balloting.

**ACTION ID:** FYI

**WORK ITEM:** Project number to be assigned.

**DUE DATE:** 2009-02-28

**DISTRIBUTION:** P and L-Members of ISO/IEC JTC1/SC17  
JTC1 Secretariat  
ISO/IEC ITTF

**MEDIUM:** SERVER

**NO. OF PAGES:** 9

---

**Identification cards – Contactless integrated circuit cards – Vicinity cards –  
Part 1: Physical characteristics**

**Contents**

**1 Scope..... 1**

**2 Normative reference(s)..... 1**

**3 Term(s) and definition(s)..... 1**

**4 Physical characteristics ..... 2**

**4.1 General..... 2**

**4.2 Antenna..... 2**

**4.3 Alternating magnetic field..... 2**

**Annex A (informative) Standards compatibility ..... 3**

**Annex B (informative) Surface quality for printing ..... 3**

**Annex C (informative) Hole slot ..... 5**

## Foreword

ISO (the International Organization for Standardization) and IEC (the International Electrotechnical Commission) form the specialized system for worldwide standardization. National bodies that are members of ISO or IEC participate in the development of International Standards through technical committees established by the respective organization to deal with particular fields of technical activity. ISO and IEC technical committees collaborate in fields of mutual interest. Other international organizations, governmental and non-governmental, in liaison with ISO and IEC, also take part in the work. In the field of information technology, ISO and IEC have established a joint technical committee, ISO/IEC JTC 1.

International Standards are drafted in accordance with the rules given in the ISO/IEC Directives, Part 3.

The main task of the joint technical committee is to prepare International Standards. Draft International Standards adopted by the joint technical committee are circulated to national bodies for voting. Publication as an International Standard requires approval by at least 75 % of the national bodies casting a vote.

Attention is drawn to the possibility that some of the elements of this document may be the subject of patent rights. ISO/IEC JTC1 shall not be held responsible for identifying any or all such patent rights.

International Standard ISO/IEC 15693-1 was prepared by Joint Technical Committee ISO/IEC JTC1, *Information technology, Subcommittee SC17, Cards and personal identification*.

This second edition cancels and replaces the first edition (ISO/IEC 15693-1:2000).

ISO/IEC 15693 consists of the following parts, under the general title *Identification cards - Contactless integrated circuit(s) cards - Vicinity cards*:

- *Part 1: Physical characteristics*
- *Part 2: Air interface and initialization*
- *Part 3: Anticollision and transmission protocols*

*Annexes A, B and C of this part of ISO/IEC 15693 are for information only.*

## Introduction

Contactless card standards encompass a variety of types as embodied in International Standards ISO/IEC 10536 (Close-coupled cards), ISO/IEC 14443 (Proximity cards) and ISO/IEC 15693 (Vicinity cards). These device types are intended, respectively, for operation when very near, nearby and at a longer distance from associated coupling devices.

ISO/IEC 15693 defines the technology-specific requirements for identification cards conforming to ISO/IEC 7810 and thin flexible cards conforming to ISO/IEC 15457-1 and the use of such cards to facilitate international interchange. However, it also recognizes that the technology offers the possibility that vicinity objects may be provided in forms other than that of the international standard card formats. Furthermore, it does not preclude the incorporation of other standard technologies on the card, such as those referenced in the informative Annex B.

ISO/IEC 15693 accommodates the operation of Vicinity cards in the presence of other contactless cards conforming to ISO/IEC 10536 and ISO/IEC 14443 standards.

# Identification cards – Contactless integrated circuit cards – Vicinity cards – Part 1: Physical characteristics

## 1 Scope

Part 1 of ISO/IEC 15693 describes the physical characteristics of vicinity cards (VICCs).

It shall be used in conjunction with other parts of ISO/IEC 15693.

## 2 Normative reference(s)

The following referenced documents are indispensable for the application of this document. For dated references, only the edition cited applies. For undated references, the latest edition of the referenced document (including any amendments) applies.

ISO/IEC 7810, *Identification cards – Physical characteristics*

ISO/IEC 10373-7, *Identification cards - Test methods – Vicinity cards*

ISO/IEC 15457-1, *Identification cards – Thin flexible cards – General characteristics*

## 3 Terms and definitions

For the purposes of this document, the terms and definitions given in ISO/IEC 7810, ISO/IEC 15457-1 and the following apply.

### 3.1 integrated circuit IC

electronic component designed to perform processing and/or memory functions

### 3.2 contactless

pertaining to the achievement of signal exchange with, and supply of power to, the card without the use of galvanic elements (i.e. the absence of an ohmic path from the external interfacing equipment to the integrated circuit(s) contained within the card)

### 3.3 contactless integrated circuit card

card into which integrated circuit and coupling means have been placed, such that communication to such integrated circuit is done in a contactless manner

### 3.4 operate as intended

operates in the manner described by the manufacturer's specification in accordance with the ISO/IEC 15693 series

### **3.5 VICC**

contactless integrated circuit card or other object with which communication and power transfer are done by inductive coupling in vicinity of a coupling device; commonly called a vicinity card

## **4 Physical characteristics**

### **4.1 General**

The VICC may be in the form of a card compliant with ISO/IEC 7810 or ISO/IEC 15457-1, or an object of any other dimension.

### **4.2 Antenna**

If the VICC dimensions are not compliant with ISO/IEC 7810 or ISO/IEC 15457-1, the dimensions of the VICC antenna shall not exceed 86 mm x 54 mm x 3 mm.

NOTE This antenna size restriction stems from the fact that the radio frequency power and signal interface defined in ISO/IEC 15693-2 and its test methods in ISO/IEC 10373-7 are based on ID-1 cards.

### **4.3 Alternating magnetic field**

The VICC, whichever form the VICC has according to 4.1, shall continue to operate as intended after continuous exposure to a magnetic field of an average level of 10 A/m rms at 13,56 MHz. The averaging time is 30 seconds and the maximum level of the magnetic field is limited to 12 A/m rms.

## **Annex A (informative) Standards compatibility**

This part of ISO/IEC 15693 does not preclude the application to the VICC of other existing card technology standards, such as those listed as follows:

- ISO/IEC 7811, *Identification cards - Recording technique*;
- ISO/IEC 7812, *Identification cards - Identification of issuers*;
- ISO/IEC 7813, *Identification cards - Financial transaction cards*;
- ISO/IEC 7816, *Identification cards - Integrated circuit(s) cards with contacts*;
- ISO/IEC 10536, *Identification cards - Contactless integrated circuit(s) cards - Close-coupled cards*;
- ISO/IEC 14443, *Identification cards - Contactless integrated circuit(s) cards - Proximity cards*;
- ISO/IEC 15457, *Identification cards – Thin flexible cards*;

NOTE Restrictions may apply to embossing of VICCs (see ISO/IEC 7811-3).



**Annex B**  
**(informative)**  
**Surface quality for printing**

Where there is a requirement to customize the VICC after the manufacturing process by overprinting, care should be taken to ensure the areas used for printing are of sufficient quality appropriate to the printing technique or printer used.

## Annex C (informative)

### Hole slot

When a slot is optionally implemented the slot size and slot location should be as shown in either Figure C.1 or Figure C.2.

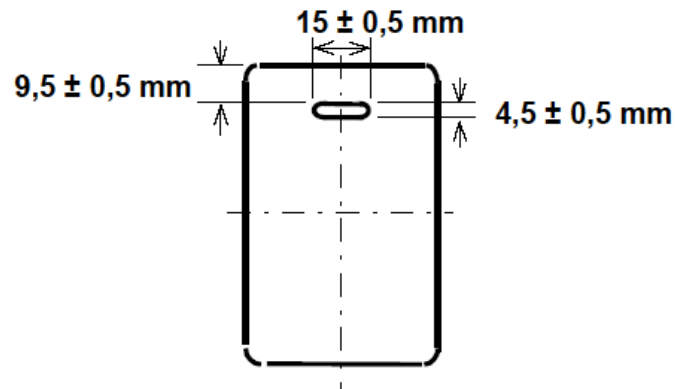

Figure C.1 — Hole Slot for Portrait Orientation

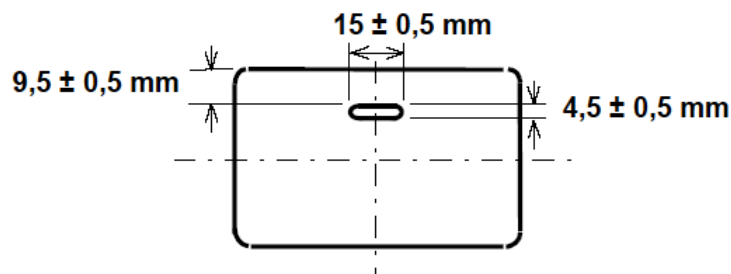

Figure C.2 — Hole Slot for Landscape Orientation

The VICC IC(s) and inductive coupling element shall be positioned such that either slot as shown in Figure C.1 and Figure C.2 can be implemented without interference to either the IC(s) or inductive coupling element.

**WARNING** — Cards with hole slots may cause problems in automatic card handling equipment, for example cash dispensers.