

ISO/IEC JTC 1/SC 17
Cards and personal identification
Secretariat: BSI

Document type: Text for FPDAM ballot or comment

Title: Notification of Ballot: ISO/IEC FPDAM 1.2 14443-4:2008 - Identification cards - Contactless integrated circuit(s) cards - Proximity integrated circuit(s)cards - Part 4: Transmission protocol - Amendment 1:Exchange of additional parameters.

Status: **Backward Pointer:** N 3707, N 3708, N 3779, N 3844, N 3845, N 3879 and N 3929.
Status: This ballot has been posted to the ISO Electronic balloting application and is available under the Balloting Portal, Committee Internal Balloting.
Disposition of comments on PDAM are contained in N 3929.
Work Item:54823

Date of document: 2010-05-28

Expected action: VOTE

Action due date: 2010-09-26

No. of pages: 8

Email of secretary: chris.starr@ukpayments.org.uk

Committee URL: <http://isotc.iso.org/livelink/livelink/open/jtc1sc17>

ISO/IEC JTC 1/SC 17 N

Date: 2010-05-4

ISO/IEC 14443-4:2008/FPDAM 1

ISO/IEC JTC 1/SC 17/WG 8

Secretariat: DIN

Identification cards — Contactless integrated circuit(s) cards - Proximity cards — Part 4: Transmission protocol

AMENDMENT 1: Exchange of additional parameters

Cartes d'identification — Cartes à circuit(s) intégré(s) - cartes de proximité — Partie 4: Protocol de transmission

Warning

This document is not an ISO International Standard. It is distributed for review and comment. It is subject to change without notice and may not be referred to as an International Standard.

Recipients of this draft are invited to submit, with their comments, notification of any relevant patent rights of which they are aware and to provide supporting documentation.

Document type: International Standard
Document subtype: Amendment
Document stage: (30) Committee
Document language: E

D:\C2\B\wg8.de\TOTAL_WG8_Website\wg8.de_offline\secure\xxxwg8n1684_New_Text_of_2ndCD14443-4_2008_AMD1.rtf STD Version 2.1c2

Copyright notice

This ISO document is a working draft or committee draft and is copyright-protected by ISO. While the reproduction of working drafts or committee drafts in any form for use by participants in the ISO standards development process is permitted without prior permission from ISO, neither this document nor any extract from it may be reproduced, stored or transmitted in any form for any other purpose without prior written permission from ISO.

Requests for permission to reproduce this document for the purpose of selling it should be addressed as shown below or to ISO's member body in the country of the requester:

[Indicate the full address, telephone number, fax number, telex number, and electronic mail address, as appropriate, of the Copyright Manger of the ISO member body responsible for the secretariat of the TC or SC within the framework of which the working document has been prepared.]

Reproduction for sales purposes may be subject to royalty payments or a licensing agreement.

Violators may be prosecuted.

Contents

Page

Foreword.....iv

Foreword

ISO (the International Organization for Standardization) and IEC (the International Electrotechnical Commission) form the specialized system for worldwide standardization. National bodies that are members of ISO or IEC participate in the development of International Standards through technical committees established by the respective organization to deal with particular fields of technical activity. ISO and IEC technical committees collaborate in fields of mutual interest. Other international organizations, governmental and non-governmental, in liaison with ISO and IEC, also take part in the work. In the field of information technology, ISO and IEC have established a joint technical committee, ISO/IEC JTC 1.

International Standards are drafted in accordance with the rules given in the ISO/IEC Directives, Part 2.

The main task of the joint technical committee is to prepare International Standards. Draft International Standards adopted by the joint technical committee are circulated to national bodies for voting. Publication as an International Standard requires approval by at least 75 % of the national bodies casting a vote.

Attention is drawn to the possibility that some of the elements of this document may be the subject of patent rights. ISO and IEC shall not be held responsible for identifying any or all such patent rights.

Amendment 1 to ISO/IEC 14443-4:2008 was prepared by Joint Technical Committee ISO/IEC JTC 1, *Information technology, Subcommittee SC 17, Card and personal identification*.

Identification cards — Contactless integrated circuit(s) cards - Proximity cards — Part 4: Transmission protocol

Amendment 1: Exchange of additional parameters

Page 14 of ISO/IEC 14443-4:2008, add before 3rd paragraph the following paragraph:

"A mechanism is provided in order to introduce additional protocol functions that may be defined from time to time in this standard or in other standards that use this standard as their foundation"

Page 15 of ISO/IEC 14443-4:2008, 7.1.1.1

Replace the 3rd dash with:

"S-block used to exchange control information between the PCD and the PICC. The support of the S(PARAMETERS) block is optional for PCDs and PICCs. Three different types of S-blocks are defined:

- 1) "Waiting time extension" containing a 1 byte long INF field,
- 2) "DESELECT" containing no INF field,
- 3) "PARAMETERS" containing a n-byte long INF field with $n \geq 0$. FSD and FSC should be greater or equal to 128 bytes."

Replace the last paragraph with:

"A PICC or PCD setting $b6 \neq 0b$ of an I-block is not compliant with this standard. A PICC or PCD setting $b2 \neq 1b$ of an R-block is not compliant with this standard. A PICC or PCD setting $b1 \neq 0b$ of an S-block is not compliant with this standard. A PICC or PCD not supporting S(PARAMETERS) and setting $b2 \neq 1b$ of an S-block is not compliant with this standard."

Replace figure 17 with

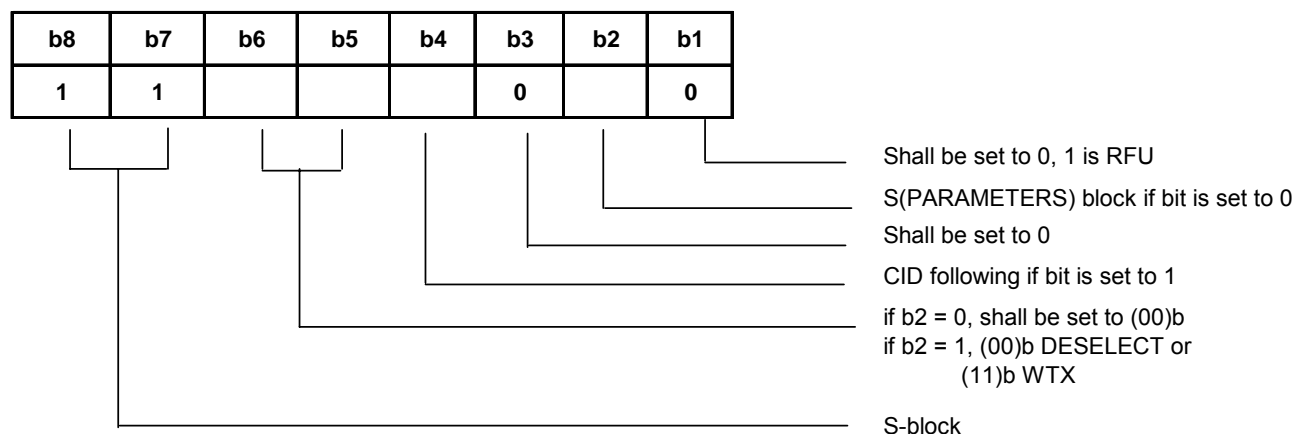

Figure 17 — Coding of S-block PCB

Page 18 of ISO/IEC 14443-4:2008, 7.2

Replace the 2nd paragraph with:

"FWT is calculated by the following formula:

$$\text{FWT} = (256 \times 16 / fc) \times 2^{\text{FWI}}$$

where the value of FWI has the range from 0 to 14 and the value of 15 is RFU. The default value of FWI is 4 (which gives a FWT value of ~ 4,8 ms) in the two following cases:

- for Type A, if TB(1) is omitted,
- for S(PARAMETERS) and S(DESELECT) blocks."

Page 20 of ISO/IEC 14443-4:2008, 7.5

Create a new 7.5.1 and renumber all subsequent subclauses:

"7.5.1 S(PARAMETERS) blocks

After the activation sequence, the PCD may send at any time a first S(PARAMETERS) block to check if S(PARAMETERS) blocks are supported by the PICC.

This first PCD S(PARAMETERS) block and the PICC answer (if the PICC supports S(PARAMETERS) blocks) may contain information indicating the support of different application protocol types and/or other communication parameters.

The content of the S(PARAMETERS) INF field is defined in the relevant part of ISO/IEC 14443 and shall comply with the BER-TLV encoding rules for the contextual class according to ISO/IEC 7816-4."

Page 22 of ISO/IEC 14443-4:2008, 7.5.4.2 (renumbered to 7.5.5.2)

Replace rule 4 with:

"Rule 4. When an invalid block is received or a FWT time-out occurs, an R(NAK) block shall be sent (except in the case of PICC chaining or S(DESELECT) or S(PARAMETERS))."

Replace rule 8 with:

"Rule 8. If the S(DESELECT)/S(PARAMETERS) request is not answered by an error-free S(DESELECT)/S(PARAMETERS) response the S(DESELECT)/S(PARAMETERS) request may be re-transmitted. In case of not receiving S(DESELET) the PICC may be ignored.

If the S(PARAMETERS) request is not answered by an error-free S(PARAMETERS) response the S(PARAMETERS) request may be re-transmitted."

Replace page 36 table C1 with:

Bit	I-block PCB	R-block PCB	S-block PCB DESELECT WTX S(PARAMETERS) PARAMETERS			REQB / WUPB	Slot-MARKER	SELECT	ATTRIB	HLTA	HLTB	RATS	PPS
b8	0	1	1			0	X	1	0	0	0	1	1
b7	0	0	1			0	X	0	0	1	1	1	1
b6	0 (RFU)	1	0	1	0	0	X	0	0	0	0	1	0
b5	Chaining	ACK/NAK	0	1	0	0	X	1	1	1	1	0	1
b4	CID	CID	CID			0	0	X	1	0	0	0	X
b3	NAD	0 (no NAD)	0 (no NAD)			1	1	X	1	0	0	0	X
b2	1	1 (RFU)	1	0		0	0	X	0	0	0	0	X
b1	Block number	Block number	0 (RFU)			1	1	X	1	0	0	0	X

Table C.1 — Block and frame coding

In the Annex B of ISO/IEC 14443-4:2008, add the following scenarios page 29 after scenario 9

B2.6 Exchange of additional parameters

	Comment	Block No. (0)	PCD		PICC	Block No. (1)	Comment
1.	rule 1		I(0)0	====>		0	rule D
2.	rule B	1		<====	I(0)0		rule 10
3.		S(PARAMETERS) request		====>			
4.				<====	S(PARAMETERS) response		rule 3
5.			I(0)1	====>		1	rule D
6.	rule B	0		<====	I(0)1		rule 10

”

In the Annex B of ISO/IEC 14443-4:2008, add the following scenarios page 34 after scenario 24

“Scenario 25: Exchange of additional parameters

	Comment	Block No. (0)	PCD		PICC	Block No. (1)	Comment
1.	rule 1		I(0)0	====>		0	rule D
2.	rule B	1		<====	I(0)0		rule 10
3.		S(PARAMETERS) request		====>			
4.	time-out			<====	-		
5.	rule 8	S(PARAMETERS) request		====>			
6.				<====	S(PARAMETERS) response		rule 3
7.			I(0)1	====>		1	rule D
8.	rule B	0		<====	I(0)1		rule 10

”